

STEELUS

EQUIPMENT

SPT38Z4

TECHNICAL DATA

TRUCK MOUNTED CONCRETEPUMP

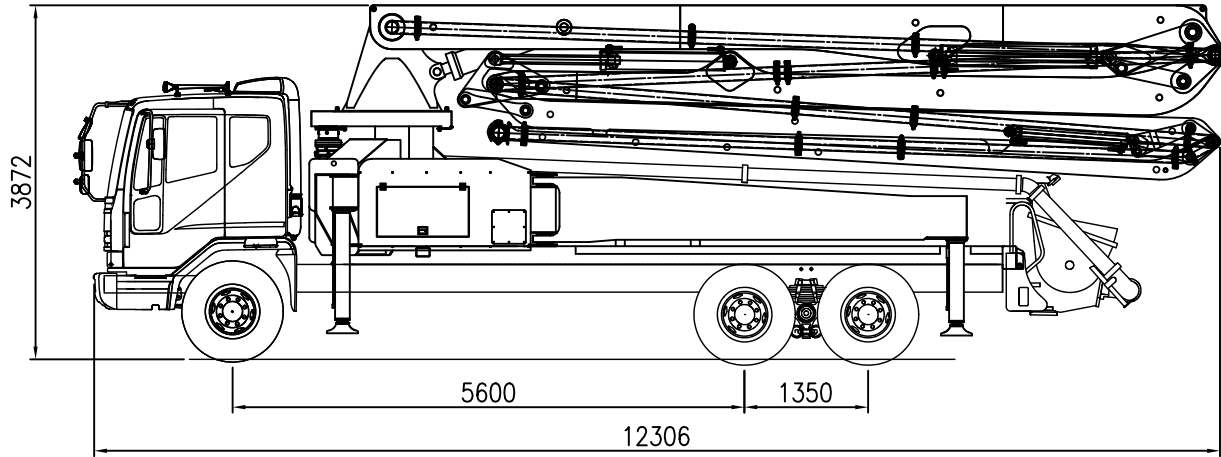

BOOM SPECIFICATIONS

Vertical Reach	36.2m
Horizontal Reach	32.5m
Reach from front of Truck	28.2m
Unfolding Height	8.4m
Depth Reach	20m
Rotation	360°
End Hose Length	3.5m
Delivery Line	125mm

PUMP SPECIFICATIONS

Max. Output	162m ³ /h
Concrete Cylinder	ø230x2100
Stroke per Minute	30
Concrete Pressure	70bar
Hopper Capacity	0.6m ³
S-Tube	S2018
Hydraulic Pump	REXROTH
Radio Remote	HBC
Max Aggregate Size	40mm

WORKING DIAGRAM

